

INDUSTRIAL

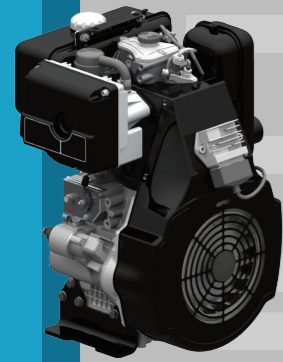

► Arranque eléctrico y stop manual

M431

1431-5002 1.720€

M540

.224-4732 2.020€

23196 Cuadro START 80€

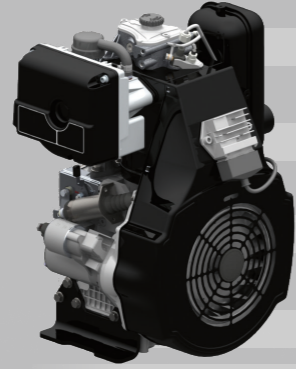

► Electroimán

M431

1431-5015 1.800€

M471

13900 1.800€

M540

.224-4758 2.120€

.226-1045 Depósito 40 l. 210€

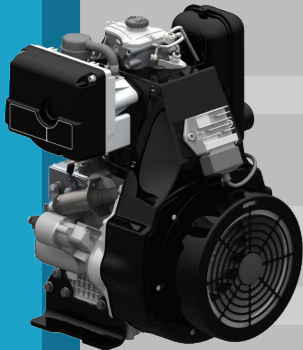

► Lento 1.500 r.p.m.

M608

.241-5007 2.620€

.226-1045 Depósito 40 l. 210€

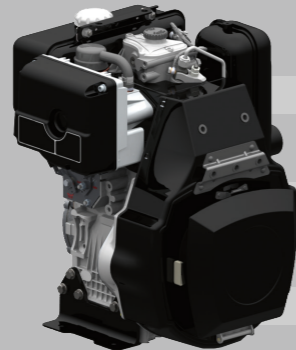

► Arranque cuerda.

M431

1431-4432 1.430€

M540

.224-4724 1.750€

CONTRAINCENDIOS

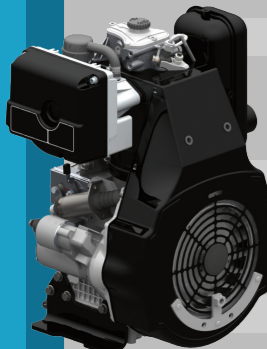

► Sin depósito

M471

FAE	VDO	
13935	13937	1.910€

M600

FAE	VDO	
23297	.226-4846	2.230€

.226-1045 Depósito 40 l. 210€

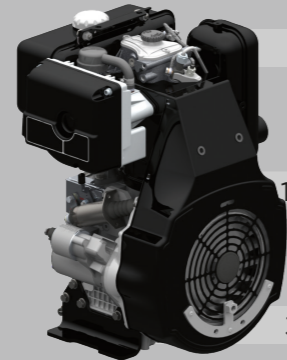

► Con depósito

M471

FAE	VDO	
13934	13939	2.000€

M600

FAE	VDO	
3446	12566	2.310€

...934-032 Tuberías flexibles Ø50 - 2,5 m 75€

AGRÍCOLA

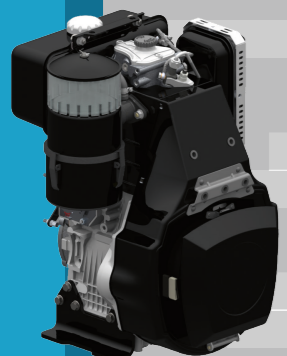

► Arranque cuerda

M431

1431-4744
1.420€

M540

.224-4742
1.730€

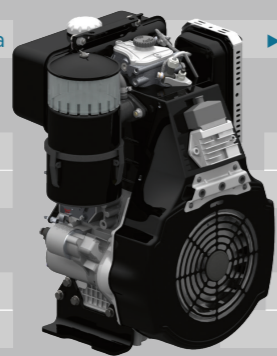

► Arranque eléctrico

M431

1431-4747
1.720€

M540

.224-4848
2.040€

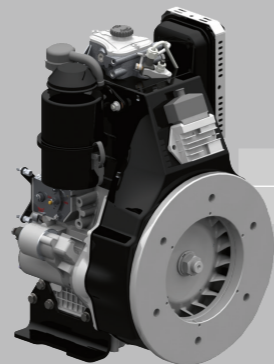

M605

1241-0007
2.350€

RECOGEFRUTAS

**MOTOR DIESEL
MONOCILÍNDRICO**

REFRIGERADO POR AIRE

2024

www.minsel.es

INDUSTRIAL

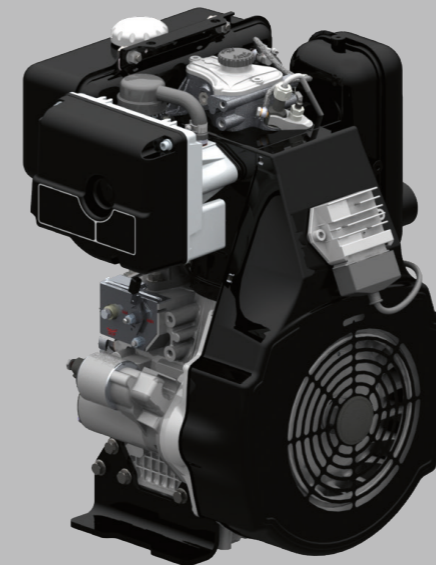

Filtro aire-seco.
Acelerador industrial.

CONTRAINCENDIOS

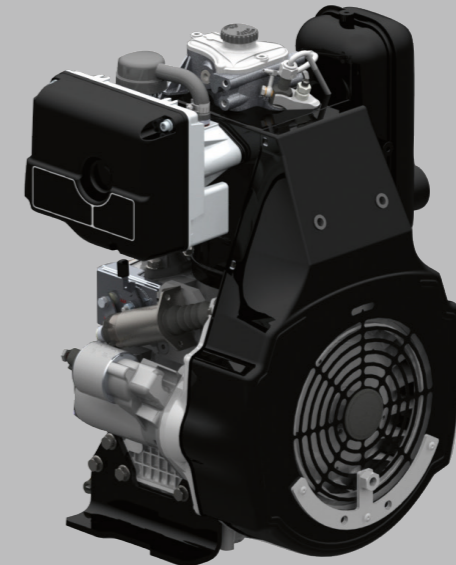

Electroimán.
Lecturas FAE VDO.

AGRÍCOLA

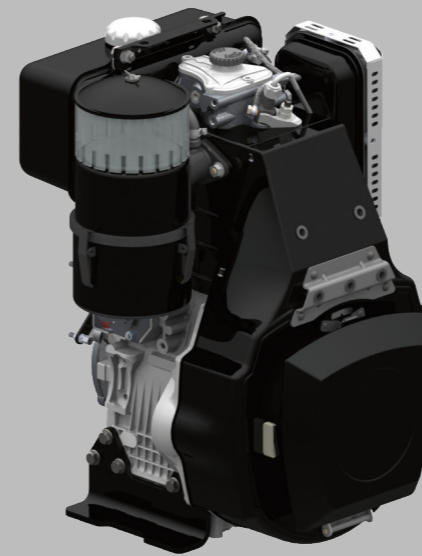

Filtro baño en aceite.
Acelerador y stop agrícola.

RECOGEFRUTAS

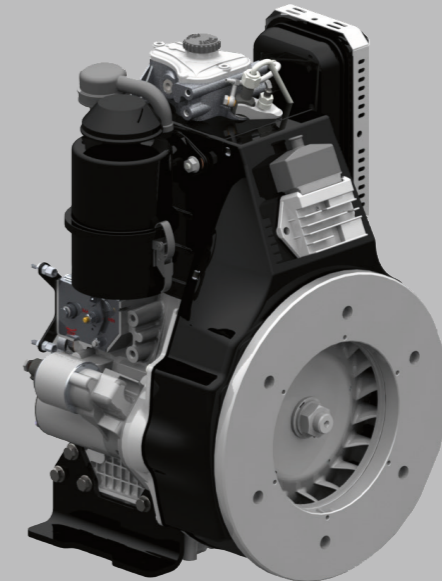

Filtro baño en aceite.
1.600 r.p.m.

Gama
M431
M471
M540
M604
RF/RD